

Iron Globe Valves

PN16/235PSI/Class125

Outside Screw and Yoke, Bronze Seat

Design to BS5152 and MSS SP-85

Flange Dimension to EN1092-2, ANSI B16.1 Class 125

Hydraulic Pressure Test	
Body	2.4Mpa/24Bar
Seat	1.76Mpa/17.6Bar

Pressure Ratings	
	1.0 Mpa at 180°C
	1.6 Mpa at -10°C-120°C



GL670-R

2" - 12"

Materials List

No	Part	Specification	BS EN	ASTM
1	Body	Cast Iron	BSEN 1561	A126 Class B
2	Seat Sealing Ring	Cast Bronze	1982 CC491K	B62
3	Disc Sealing Ring	Cast Bronze	1982 CC491K	B62
4	Disc	Cast Iron	BSEN 1561	A126 Class B
5	Thrust Washer	Stainless Steel	BSEN 10088-1	AISI 304
6	Nut	Cast Brass	12164 CW603N	B16
7	Stem	Brass	12164 CW603N	B16
8	Flange Gasket	Graphite	---	--
9	Bolt	Steel	BSEN 10087	Steel A307
10	Packing	Graphite	---	--
11	Bonnet	Cast Iron	BSEN 1561	A126 Class B
12	Seal Gland	Ductile Iron	BSEN 1563	A536 65-45-12
13	Nut	Steel	BSEN 10087	Steel A307
14	Bolt	Steel	BSEN 10087	Steel A307
15	Stem Nut	Cast Brass	12164 CW603N	B16
16	Handwheel	Cast Iron	BSEN 1561	A126 Class B
17	Gasket	Steel	BSEN 10087	Steel A307
18	Nut	Steel	BSEN 10087	Steel A307

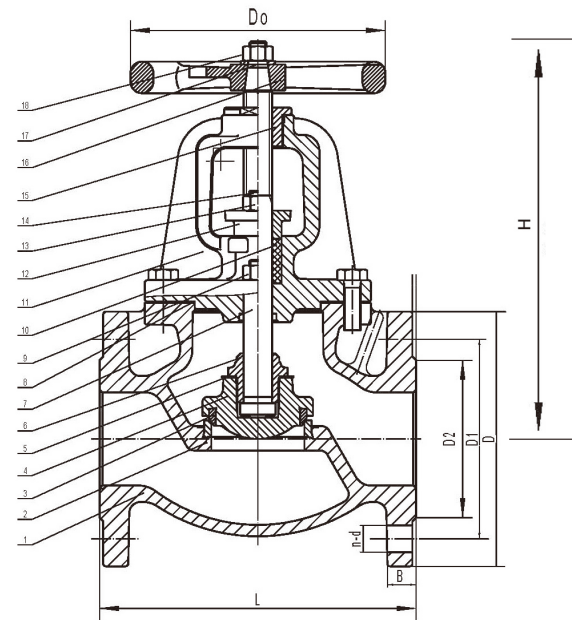

Dimensions-Weights

mm	50	65	80	100	125	150	200	250	300
In	2	2 1/2	3	4	5	6	8	10	12
L	203	216	241	292	330	356	495	622	699
H	315	345	387	490	576	680	808	1010	1080
D	165	185	200	220	250	285	340	405	460
D1	125	145	160	180	210	240	295	355	410
D2	99	118	132	156	184	211	266	319	370
D0	178	178	200	254	300	300	348	400	457
B	20	20	22	24	26	26	30	32	32
n-d	4-19	4-19	8-19	8-19	8-19	8-23	12-23	12-28	12-28
Weight	Lbs	34	47	68	99	151	204	346	673
	Kg	16	22	31	45	68	93	157	305